

## New unique solution in leak detection for double-walled tanks and pipes

**SGB's new solution for monitoring tanks with lining or the change over from liquid leak detection to vacuum monitoring**



Vacuum leak detector VLXE .. M | © SGB

### **Vacuum leak detector VLXE .. M**

The VLXE .. M is a new development in vacuum leak detection by SGB and offers a completely new and unique solution in leak detection for double-walled tanks and pipes.

Top features are:

- Explosion protected design for monitoring petrol or gasoline
- Weather proofed stainless steel box in IP 54
- CPU controlled pressure sensor
- Integrated System-Tightness-Test of the monitored system
- Digital display in front cover for quick pressure control
- Membrane keypad for a clean and easy touch
- Working temperature till -40°C
- Suitable for tanks with petrol leak protection lining
- Available also with remote monitoring LOD

Due to the safe and continuous monitoring each leak will reliably be indicated – regardless whether the leak is in the inner or outer wall. And this before any stored or transported fluid can damage the environment.

Examples of installations:

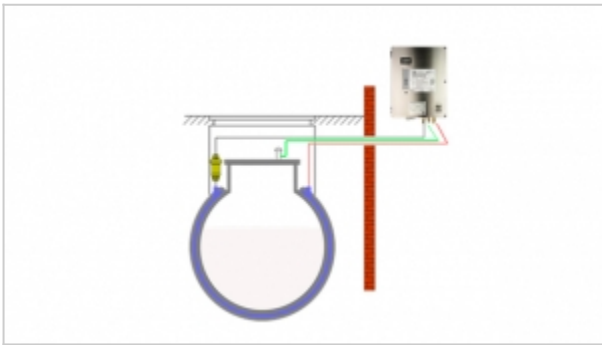

Tanks with lining or double-walled steel tanks | © SGB

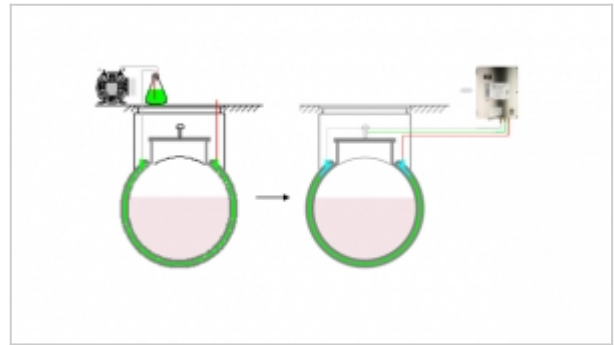

Change over from liquid leak detection to vacuum monitoring | © SGB

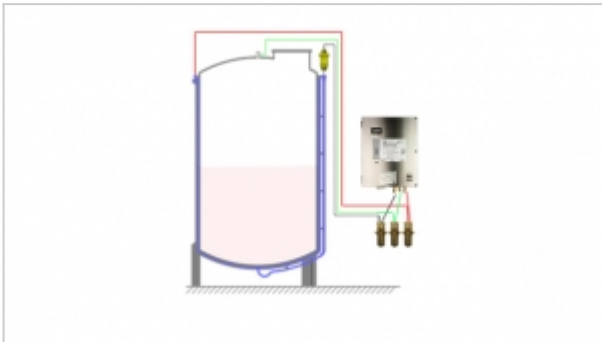

Vertical cylindrical tanks | © SGB

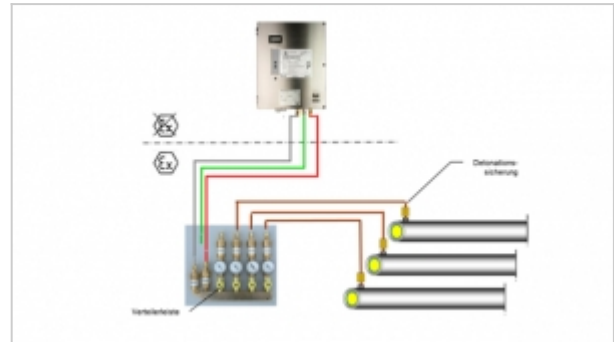

Pipes | © SGB

## Contact information

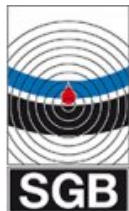

**SGB GmbH**  
Hofstr. 10  
57076 Siegen  
Germany

 +49 271 48964 0

 +49 271 48964 6

 [www.sgb.de](http://www.sgb.de)